

MODEL# **10D**

## UL762 UPBLAST EXHAUST FAN DIRECT DRIVE

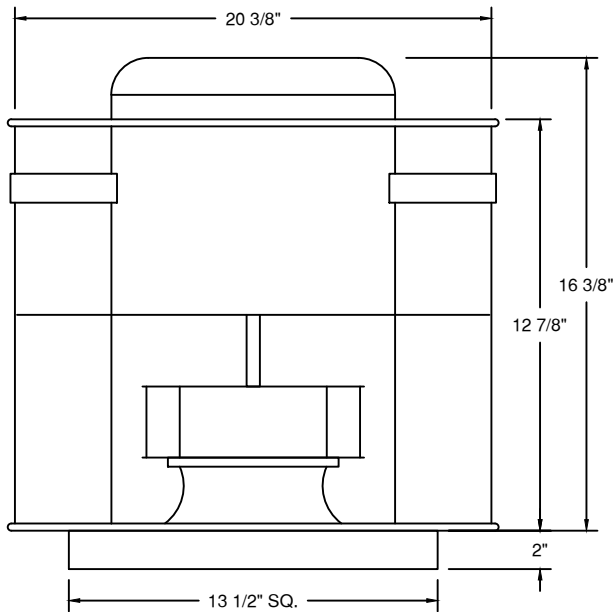

**DIMENSIONAL DATA**  
12" SQ. CURB

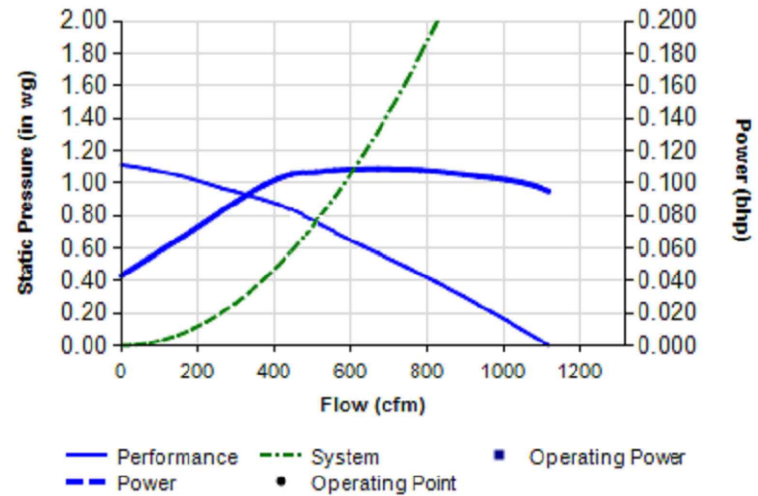

### PERFORMANCE DATA

PHASE	1	VOLTS	115
AMPS	3.3	HP	1/10

RPM	.000" S.P.		.125" S.P.		.250" S.P.		.375" S.P.		.50" S.P.		.625" S.P.		.750" S.P.	
	CFM	Sone	CFM	Sone	CFM	Sone	CFM	Sone	CFM	Sone	CFM	Sone	CFM	Sone
1550	1017	10.1	951	10.2	885	10.6	816	9.6	731	9.5	617	9.5	506	9.5

### STANDARD FEATURES

#### UL762

- HEAVY GAUGE ALUMINUM HOUSING
- 1 YEAR LIMITED WARRANTY ON ALL ELECTRIC MOTORS
- FACTORY SET DRIVE
- BELT DRIVEN MOTORS ARE ENCLOSED IN WEATHER-TIGHT COMPARTMENTS
- AVERAGE UNIT WEIGHT: 30 LBS
- AVERAGE SHIPPING WEIGHT: 43 LBS



FANS  
**UL 762**